

MICRO SWITCH™ Switches in Conveyor Applications

BACKGROUND

A belt conveyor usually consists of two or more pulleys, with a continuous loop of material (belt) that rotates about them. One or both of the pulleys are powered, moving the belt and the material on the belt forward. There are two main industrial classes of belt conveyors: general material handling (moving boxes along inside a factory) and bulk material handling (transporting industrial/agricultural materials). (See Figure 1.)

Figure 1. Boxes Moving Along Conveyor



SOLUTIONS

Honeywell manufactures many MICRO SWITCH™ switches that may be used in conveyor applications. They are designed to help control position, flow, and machine safety. (See Fig 2.)

One of the broadest and deepest limit switch portfolios available. Honeywell MICRO SWITCH™ limit switches are rugged, dependable position detection solutions. Honeywell offers an advanced line of heavy-duty limit switches and a wide selection of application-proven enclosed switches. Products meet or exceed critical standards allowing for global use. Honeywell solutions for machine guarding applications include operator point-of-operation protection, access detection, presence sensing, gate monitoring, and electrical interfacing. Series includes safety interlock, limit, cable pull, and non-contact switches. Honeywell MICRO SWITCH™ safety switches are high-quality, dependable, and cost-effective solutions for safety hardguarding and perimeter emergency stop applications. Most are SIL 3 capable.

MICRO SWITCH™ explosion-proof switches are the industry standard for hazardous applications. Available in a variety of styles, MICRO SWITCH™ hazardous location switches feature UL, CSA, ATEX, and IEC Ex certifications. Offered with a variety of heads and non-sparking actuators, Honeywell's hazardous location switch product line includes smaller sizes, lower-cost options, and analog outputs.

Figure 2. Honeywell Products Potentially Used in Conveyors

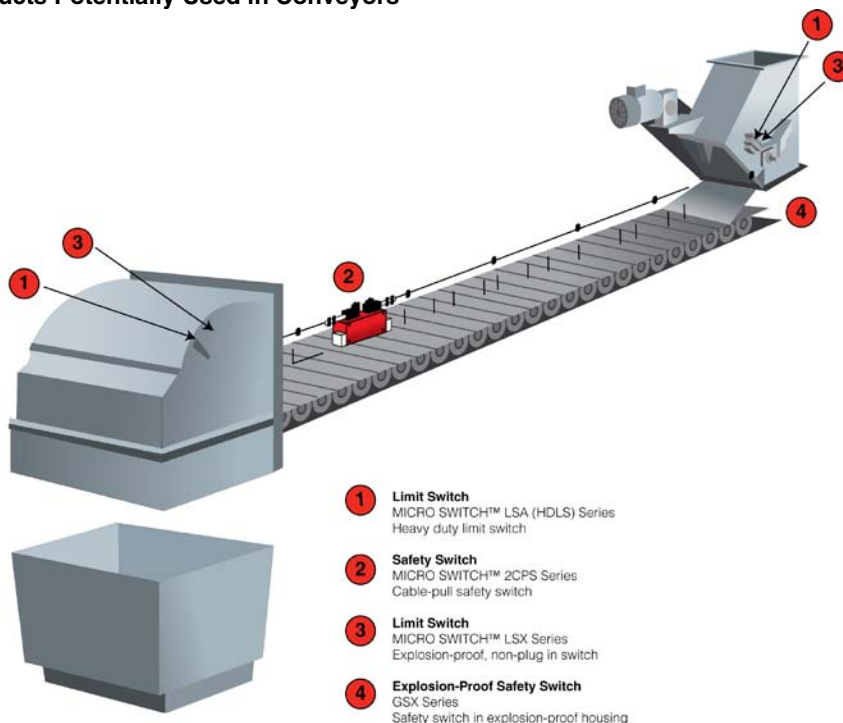

MICRO SWITCH™ Switches in Conveyor Applications

Table 1. MICRO SWITCH Limit Switches in Conveyor Applications



LSA Series (HDLS) Heavy-Duty Limit Switches	Features and Benefits
	<ul style="list-style-type: none"> • Rugged design for dependability • Environmental sealing for use in many harsh environments • Samples and drawings readily available for fast design-in time • Rapid customization and short lead times • Convenience of on-the-spot adjustment instructions • Complete choice of circuitry and electrical rating options • Stainless steel (NEMA 4X) versions and epoxy filled wash down (NEMA 6P) types

Table 2. MICRO SWITCH Safety Switches in Conveyor Applications

1CPS and 2CPS Series Cable-Pull Safety Switch	GSX Series Explosion-Proof Housing Switch
	
Features and Benefits	
<ul style="list-style-type: none"> • Safe, reliable operations in harsh environments • Maximize uptime by minimizing false alarms • Easily detectable machine faults at startup • Lower installed cost • Easy to use and maintain • SIL 3 capable 	<ul style="list-style-type: none"> • Safe, reliable operation with global certifications • Reliability in potentially explosive and hazardous applications in harsh weather or environmental conditions • Flexible design options with broad range of sizes, orientations and electrical loads • Positive-break safety switch in explosion-proof housing

MICRO SWITCH™ Limit Switches

MICRO SWITCH™ LSA Series (HDLS) heavy-duty limit switch: On conveyors, heavy-duty limit switches are often used to reliably indicate position to system controls, often found in many harsh indoor and outdoor environments.

Honeywell Sensing and Control offers an advanced line of MICRO SWITCH™ heavy-duty limit switches. Heavy-duty switches offer a rugged, die-cast body — epoxy-coated — with multiple mounting and actuator options. Low- and high-temp construction and factory-sealed, pre-wired versions are also available. Available with a variety of actuators, electrical specifications, terminations, circuitries and sealing ratings, Honeywell Sensing and Control's limit switches offer superior flexibility and performance. These precision snap-action switches — sealed in rugged housings — are used to detect presence or absence in areas where physical contact is allowed. (See Table 1).



MICRO SWITCH™ Safety Switches

MICRO SWITCH™ 2CPS Series cable-pull limit switch: These emergency stop switches often control access around the conveyor perimeter or provide emergency-stop cable-pulls along the conveyor

The CPS (cable-pull limit switch) Series was designed specifically to meet the requirements of major OEMs within the conveying and material handling industries. The chief requirement: engineering a highly reliable, highly visible, safe-to-use rope-pull device to protect operators working near conveying systems. The dual head span offers the longest reach in the industry, with a typical span of 76 m [250 ft] and longer versions available. The product boasts direct opening action of normally closed contacts if an emergency occurs, and the highly visible status indicator makes it easy to identify a tripped switch in an emergency. The extremely rugged design is appropriate for most harsh environments or applications, and the 2CPS is SIL 3 capable. Rugged, die-cast zinc housing minimizes false triggers in varying temperature environments (i.e., semi-enclosed conveyor spaces). Easy wiring and setup minimizes installation time. (See Table 2).

MICRO SWITCH™ Switches in Conveyor Applications

Table 3. MICRO SWITCH™ Hazardous Location Switches in Conveyor Applications

LSX Series Non-Plug In Switch	GSX Series Explosion-Proof Housing Switch
	
Features and Benefits	
<ul style="list-style-type: none"> • Safe, reliable operations in harsh environments • Maximize uptime by minimizing false alarms • Easily detectable machine faults at startup • Sealing: applicable portions of NEMA 1, 3, 4, 6, 7, 9, 13 • Variety of heads and non-sparking actuators • Field adjustability matches switch to application • Momentary, maintained, sequential, or center-neutral action 	<ul style="list-style-type: none"> • Safe, reliable operation with global certifications • Reliability in potentially explosive and hazardous applications in harsh weather or environmental conditions • Flexible design options with broad range of sizes, orientations and electrical loads • Positive action push plunger breaks current upon opening of door or aperture • cULus, ATEX, IEC Ex

MICRO SWITCH™ Safety and Hazardous Location Switches

GSX Series safety switch in an explosion-proof housing: Often used in outdoor, above-ground, potentially explosive environments, such as grain handling conveyors, or oil and gas applications. Utilized to stop system operation when the switch is triggered.

MICRO SWITCH™ GSX Series Explosion-Proof Safety Switches combine the world-class MICRO SWITCH™ global safety switch (GSS) with the superior explosion-proof housing from our LSX and BX product lines, offering customers the best of Honeywell’s engineering expertise. The positive-break feature is designed to provide a safe failure mode, ensuring the machine will not start, and therefore supporting a safer work environment. The GSX Series switch platform allows for over 10,000 actuator and switch combinations. (See Tables 2 & 3.)

MICRO SWITCH™ Hazardous Location Switches

MICRO SWITCH™ LSX Series hazardous location non-plug-in switch: Used to stop system operation when the switch is triggered. Often applied for door or diverter position detection in outdoor, above-ground, potentially explosive environments, such as grain handling and oil/gas applications.

MICRO SWITCH™ LSX switches are for use either indoors or outdoors in hazardous atmospheres as they are a completely sealed, explosion-proof device. The MICRO SWITCH™ LSX withstands pressure of an internal explosion and cools the exploding gases below the kindling temperature of the explosive atmosphere. Flame paths are provided by the cover-housing threads and an extended plunger between the switch cavity and head. (See Table 3).

MICRO SWITCH™ Switches in Conveyor Applications

WARNING

PERSONAL INJURY

DO NOT USE these products as safety or emergency stop devices or in any other application where failure of the product could result in personal injury.

Failure to comply with these instructions could result in death or serious injury.

WARRANTY/REMEDY

Honeywell warrants goods of its manufacture as being free of defective materials and faulty workmanship. Honeywell's standard product warranty applies unless agreed to otherwise by Honeywell in writing; please refer to your order acknowledgement or consult your local sales office for specific warranty details. If warranted goods are returned to Honeywell during the period of coverage, Honeywell will repair or replace, at its option, without charge those items it finds defective. **The foregoing is buyer's sole remedy and is in lieu of all other warranties, expressed or implied, including those of merchantability and fitness for a particular purpose. In no event shall Honeywell be liable for consequential, special, or indirect damages.**

While we provide application assistance personally, through our literature and the Honeywell web site, it is up to the customer to determine the suitability of the product in the application.

Specifications may change without notice. The information we supply is believed to be accurate and reliable as of this printing. However, we assume no responsibility for its use.

WARNING

MISUSE OF DOCUMENTATION

- The information presented in this application note is for reference only. Do not use this document as a product installation guide.
- Complete installation, operation, and maintenance information is provided in the instructions supplied with each product.

Failure to comply with these instructions could result in death or serious injury.

SALES AND SERVICE

Honeywell serves its customers through a worldwide network of sales offices, representatives and distributors. For application assistance, current specifications, pricing or name of the nearest Authorized Distributor, contact your local sales office or:

E-mail: info.sc@honeywell.com

Internet: www.honeywell.com/sensing

Phone and Fax:

Asia Pacific	+65 6355-2828 +65 6445-3033 Fax
Europe	+44 (0) 1698 481481 +44 (0) 1698 481676 Fax
Latin America	+1-305-805-8188 +1-305-883-8257 Fax
USA/Canada	+1-800-537-6945 +1-815-235-6847 +1-815-235-6545 Fax

Sensing and Control
Honeywell
1985 Douglas Drive North
Golden Valley, MN 55422
www.honeywell.com/sensing

000696-2-EN IL50 GLO Printed in USA
January 2011
Copyright © 2011 Honeywell International Inc. All rights reserved.

Honeywell