

Installation Instructions for the Heavy Duty Pressure Transducers PX3 Series, 1 bar to 50 bar | 15 psi to 700 psi

32313758
Issue B

General Information

Honeywell's PX3 Series Pressure Transducers use piezoresistive sensing technology with ASIC (Application Specific Integrated Circuit) signal conditioning in a brass housing and Metri-Pack

150 electrical connector. The PX3 Series are fully calibrated and temperature compensated from -40 °C to 125 °C [-40 °F to 257 °F].

Table 1. Electrical Specifications

Characteristic	Parameter
Supply voltage: 5 Vdc 3.3 Vdc	±0.25 Vdc ±0.25 Vdc
Over voltage and reverse voltage	±16 Vdc
Current consumption: 5 Vdc supply 3.3 Vdc supply	3.0 mA max. 1.6 mA to 2.1 mA
Short circuit protection	yes
Nominal output transfer function: 5 Vdc supply 3.3 Vdc supply	0.5 Vdc to 4.5 Vdc (ratiometric to supply) 0.33 Vdc to 2.97 Vdc (ratiometric to supply)

Table 2. Performance Specifications (At 25 °C [77 °F] and under unless otherwise noted.)

Characteristic	Parameter
Operating temperature range ¹	-40 °C to 125 °C [-40 °F to 257 °F]
Storage temperature range ¹	-40 °C to 125 °C [-40 °F to 257 °F]
Compensated temperature range	-40 °C to 125 °C [-40 °F to 257 °F]
Total Error Band ² : -20 °C to 85 °C [-4 °F to 185 °F] <-20 °C, >85 °C [<-4 °F, >185 °F]	±1.0 %FSS ±2.0 %FSS
Accuracy BFSL ³	±0.25 %FSS
Response time	<2 ms (10% to 90% step change in pressure)
Turn on time ⁴	<7 ms
EMC rating ⁵ : surge immunity (all leads) _____ electrostatic discharge _____ radiated immunity _____ fast transient burst _____ immunity to conducted disturbances _____ radiated emissions _____ radiated immunity _____	±1000 V line to ground per IEC 61000-4-5 ±4 kV contact, ±8 kV air per IEC 61000-4-2 10 V/m (80 MHz to 1000 MHz) per IEC 61000-4-3 ±1 kV per IEC 61000-4-4 3 V per IEC 61000-4-6 40 dB (30 MHz to 230 MHz), 47 dB (230 MHz to 1000 MHz) per CISPR 11 200 V/m per ISO 11452-2
Insulation resistance	>100 MOhm, 1500 Vdc
Dielectric strength	AC1500V, 1 min. or AC1800V, 1 s
Load resistance	>5 kOhm
Life	greater than 10 million full scale pressure cycles over the calibrated pressure range

¹ Dependent on external and internal seal and cable jacket materials. See Table 5 and Figure 5 for temperature range details.

² Total Error Band: The maximum deviation from the ideal transfer function over the entire compensated temperature and pressure range. Includes all errors due to offset, full scale span, pressure non-linearity, pressure hysteresis, pressure non-repeatability, thermal effect on offset, thermal effect on span, and thermal hysteresis. See Figure 1.

³ Accuracy: The maximum deviation in output from a Best Fit Straight Line (BFSL) fitted to the output measured over the pressure range at 25 °C [77 °F]. Includes all errors due to pressure non-linearity, pressure hysteresis, and pressure non-repeatability. See Figure 1.

⁴ Turn on Time: Duration from power applied until first valid output.

⁵ Tested using 1,5 m [59.1 in] cable.

Heavy Duty Pressure Transducers

PX3 Series, 1 bar to 50 bar | 15 psi to 700 psi

Issue B

32313758

Figure 1. TEB Definition and Temperature Performance

All Possible Errors

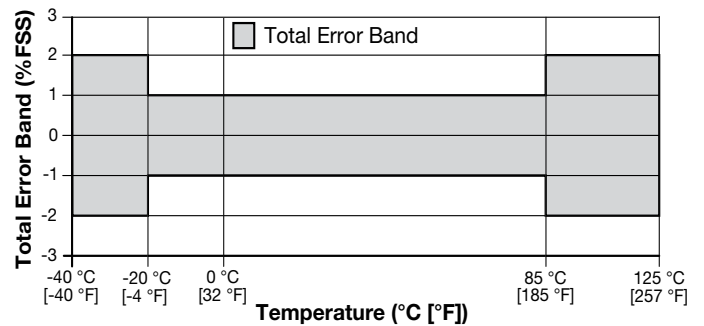
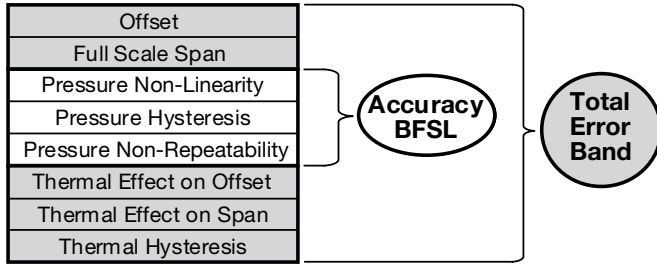

Table 3. Pressure Reference Definitions

Pressure Reference	Definition
Absolute	Output is calibrated to be proportional to the difference between applied pressure and a fixed reference to perfect vacuum (absolute zero pressure).
Sealed gage ¹	Sensor construction is identical to the absolute version with a built in reference at zero pressure in order to minimize measurement error over temperature. The output is calibrated to be proportional to the difference between applied pressure and a reference of 1 standard atmosphere (1.013 barA 14.7 psiA). Example: 100 psi sealed gage has a calibrated pressure range from 14.7 psi absolute to 114.7 psi absolute.

¹ Sealed gage option only available in pressure ranges at or above 8 bar | 100 psi.

Figure 2. Ratiometric Output Option AA for 100 psi, Absolute vs Sealed Gage

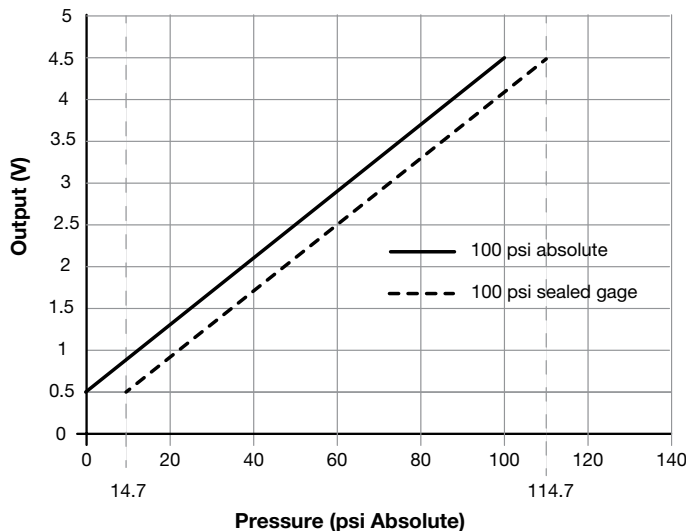

Table 4. Pressure Ratings

bar			psi		
Operating Pressure	Over-pressure	Burst Pressure	Operating Pressure	Over-pressure	Burst Pressure
1	5	8	15	70	115
1.6	5	8	30	150	250
2	10	17	50	250	400
2.5	10	17	100	450	750
4	17	27	150	450	750
6	31	51	200	450	1150
8	31	51	250	450	1150
10	31	51	300	1000	1500
16	32	80	500	1000	1500
20	69	103	600	1000	1500
25	69	103	667	1000	1500
35	69	103	700	1000	1500
40	69	103	-	-	-
46	69	103	-	-	-
50	69	103	-	-	-

Heavy Duty Pressure Transducers

PX3 Series, 1 bar to 50 bar | 15 psi to 700 psi

Issue B
32313758

Table 5. Environmental and Mechanical Specifications

Characteristic	Parameter
Shock: threaded ports tube port	100 G per MIL-STD-202G, Method 213B, Cond. F (at 25 °C [77 °F]) 100 G per MIL-STD-202F, Method 213B, and Condition C
Vibration: threaded ports tube port	20 G sweep, 10 Hz to 2000 Hz (at 25 °C [77 °F]) 10 Hz to 55 Hz, 2 mm displacement, tested as per IEC 60068-2-6; Test FC. (at 25°C [77°F])
Ingress protection: Metri-Pack 150 electrical connector cable harness electrical connector	IP67 IP69K
Ambient humidity	0 %RH to 95 %RH, non-condensing
External freeze/thaw resistance	>6 cycles from -30 °C to 50 °C [-22 °F to 122 °F]
Wetted materials: threaded ports _____ tube port _____ braze filler _____ internal media seal _____ sensing element and substrate _____ adhesives _____	brass C36000 (lead (Pb) content: 3.7% max.) copper UNS C12200 (lead (Pb) free) silver and copper alloy seal material as required by the application (see seal material media compatibility options below) alumina, glass, silicon epoxy
Internal seal material media compatibility ¹ : HNBR (option H) silicone (option S)	refrigerants, petroleum oils, lubricants air, water, hydraulic fluids
Other materials: Metri-Pack 150 electrical connector external O-ring seal on G1, M1 ports	PBT 30% GF nitrile (-30 °C to 125 °C [-22 °F to 257 °F])

¹ Honeywell can assist with selecting suitable seal material for the media based on the seal manufacturer's recommendation. The customer should test the compatibility with the media to ensure that it is correct for the application.

CAUTION PRODUCT DAMAGE

- Ensure torque specifications are determined for the specific application. Values provided are for reference only. (Mating materials and thread sealants can result in significantly different torque values from one application to the next.)
- When using mating parts made of stainless steel, use a thread sealant with anti-seize properties to prevent thread galling. Ensure the sealant is rated for the application.
- Use appropriate tools (such as an open ended wrench or deep well socket) to install transducers.
- Always hand-start transducers into the hole to prevent cross threading and damage.
- Ensure that torque is not applied to the electrical connector.
- Ensure that the proper mating electrical connector with a seal is used to connect the transducer. Improper or damaged seals can compromise ingress protection leading to short circuits.

Failure to comply with these instructions may result in product damage.

CAUTION PRODUCT DAMAGE TO TUBE PORT

Ensure that the temperature of the brass port and plastic connector is maintained below 125 °C during flame brazing. Exposure to temperatures higher than 125 °C can cause permanent product damage and can compromise ingress protection leading to short circuits.

Failure to comply with these instructions may result in product damage.

Heavy Duty Pressure Transducers

PX3 Series, 1 bar to 50 bar | 15 psi to 700 psi

Issue B

32313758

Diagnostics Mode

The PX3 Series diagnostics mode allows the device to indicate when internal or external faults occur. If an internal fault occurs, the output will rail to the preset lower or upper limit values shown in Figure 3 and Table 6.

External faults will result in the sensor's output exceeding those preset limits (lower or upper). (For example, if the external sensor ground (signal) were lost, the sensor output would exceed the upper rail of 97.5%.)

Table 6. Output Transfer Function Codes

Fault Condition	Analog Diagnostic Rail
EEPROM Corrupt	below lower rail
Sensor Bridge Open (any element)	above upper rail
Sensor Bridge Short (any element)	above upper rail
Low supply voltage	below lower rail
Loss of ground connection	above upper rail

Figure 3. Analog Output with Diagnostics

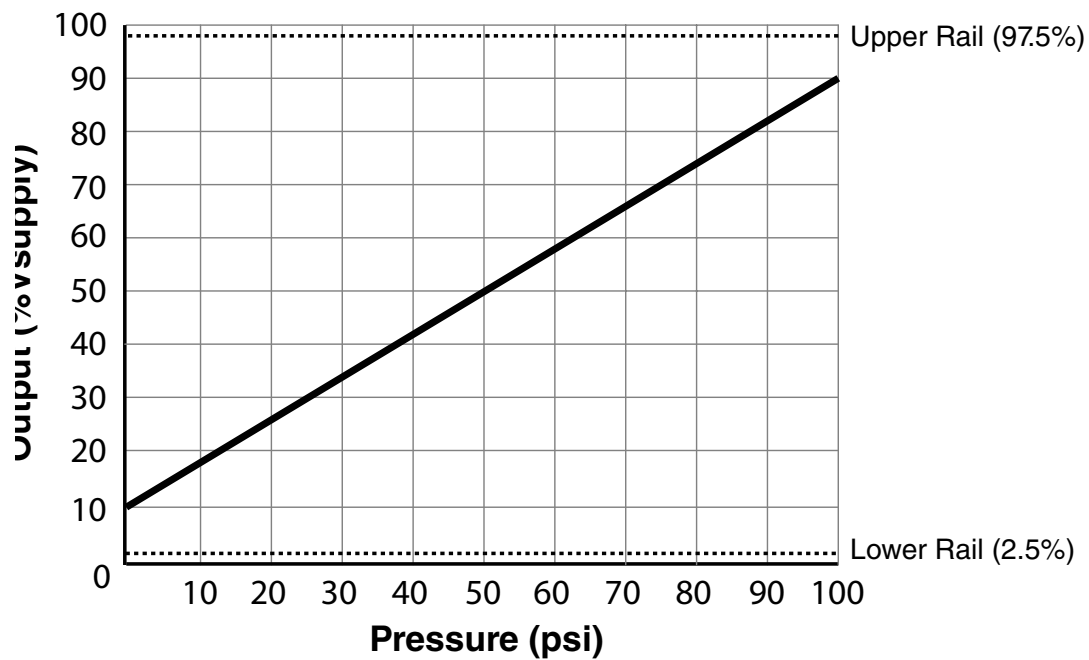

Heavy Duty Pressure Transducers

PX3 Series, 1 bar to 50 bar | 15 psi to 700 psi

Issue B

32313758

Figure 4. Metri-Pack Mounting Dimensions (For reference only, mm/[in.])

Pinout

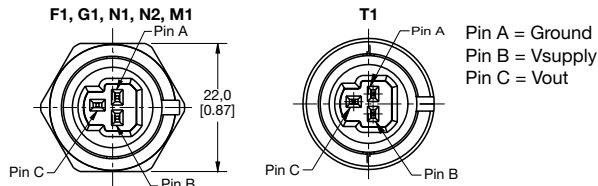

General product marking

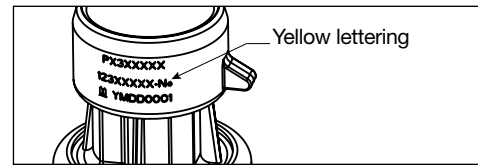

F1: 7/16-20 UNF 1/4 inch 45° Flare Female Schrader (SAE J512)

Seal: 45° cone
Mating geometry: SAE J512
Installation torque: 17 N m [12.5 ft-lb]
Weight: 54,5 g [1.9 oz]

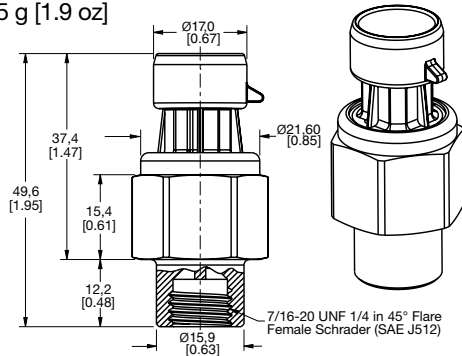

G1: G1/4 A-G (ISO 1179-3)

Seal: nitrile O-ring (included)
Mating geometry: ISO 1179-1
Installation torque: 50 N m [36.9 ft-lb]
Weight: 35,1 g [1.2 oz]

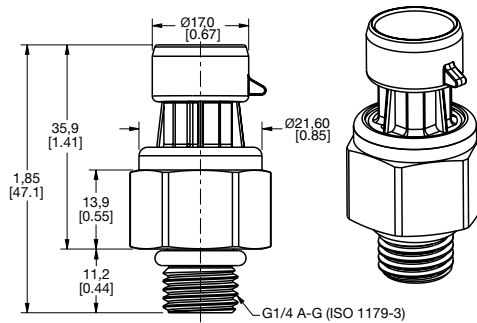

M1: M12 x 1.5 (ISO 6149-3)

Seal: nitrile O-ring (included)
Mating geometry: ISO 6149-1
Installation torque: 25 N m [18.4 ft-lb]
Weight: 33,9 g [1.2 oz]

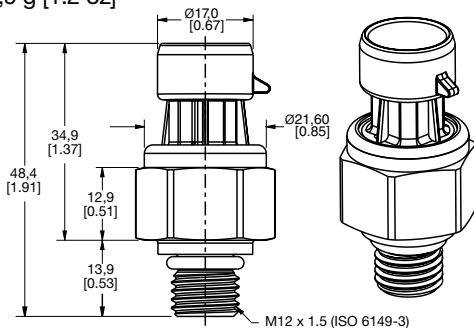

N1: 1/4-18 NPT

Seal: Pipe thread
Mating geometry: ANSI B1.20.1
Installation torque: Two to three turns from finger tight
Weight: 35,1 g [1.2 oz]

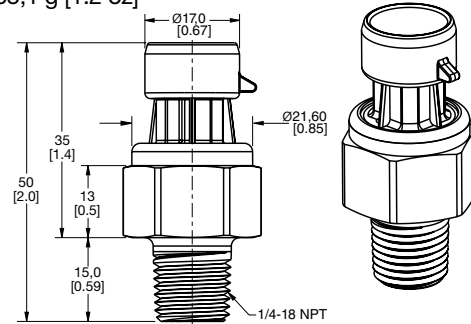

N2: 1/8-27 NPT

Seal: Pipe thread
Mating geometry: ANSI B1.20.1
Installation torque: Two to three turns from finger tight
Weight: 31,2 g [1.1 oz]

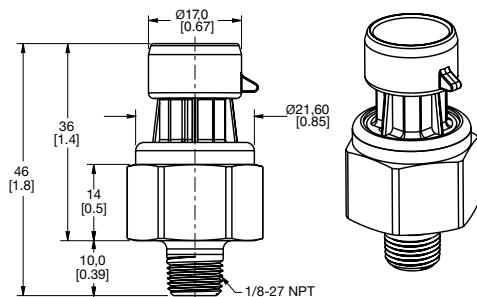

T1: Tube

Seal: Brazing
Weight: 32 g [1.1 oz]

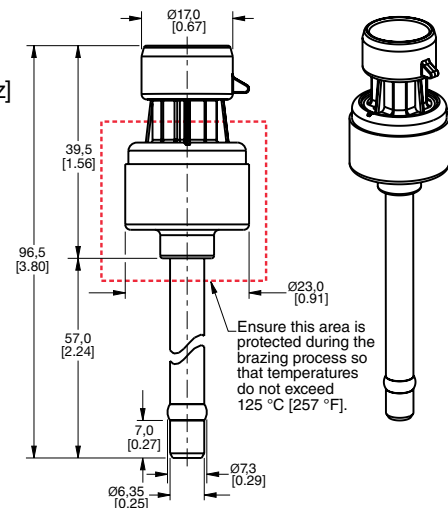

Heavy Duty Pressure Transducers

PX3 Series, 1 bar to 50 bar | 15 psi to 700 psi

Issue B

32313758

Figure 5. Cable Harness Mounting Dimensions Shown by Pressure Port Type (For reference only. mm/[in.])

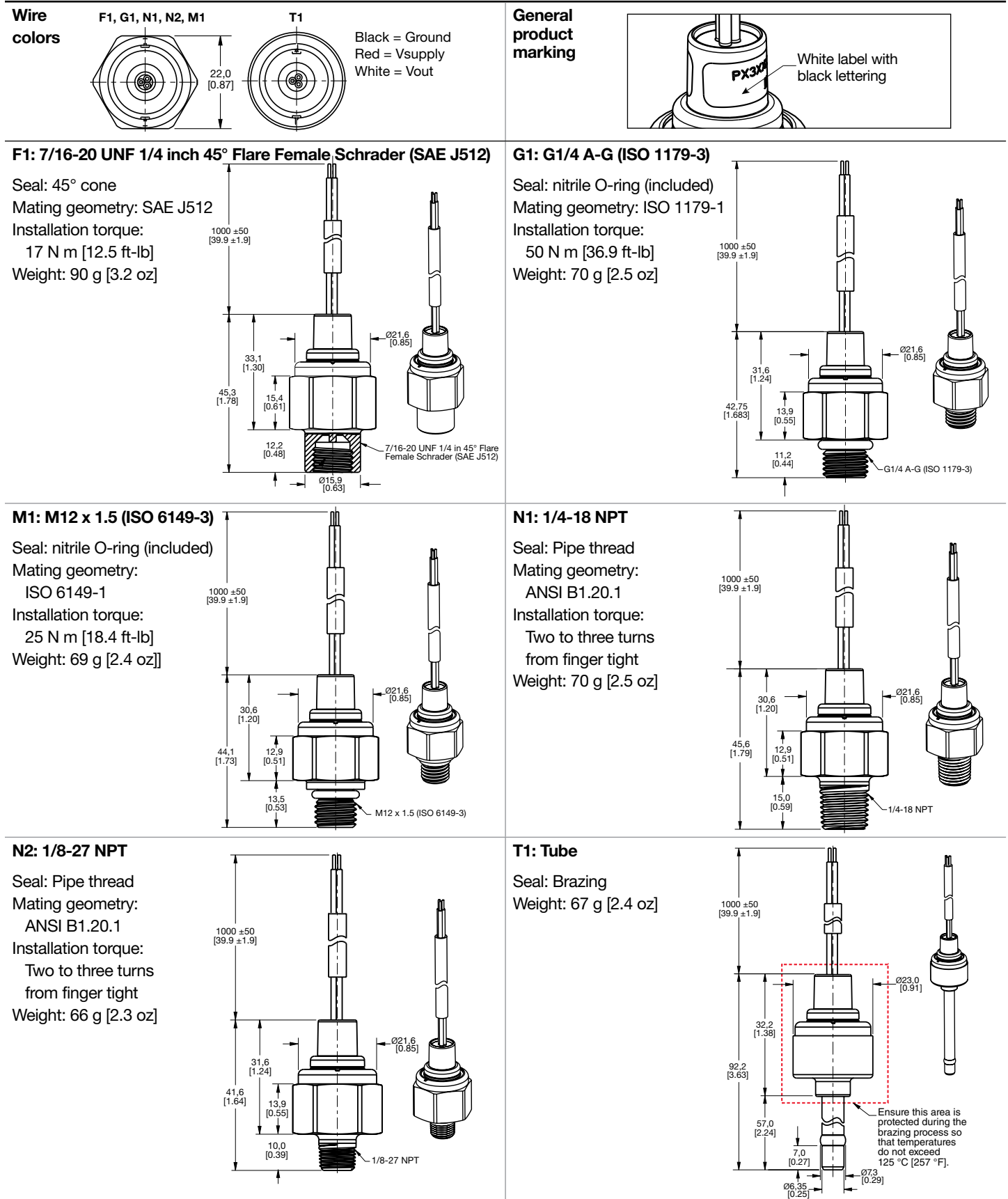

⚠ WARNING

PERSONAL INJURY

DO NOT USE these products as safety or emergency stop devices or in any other application where failure of the product could result in personal injury.

Failure to comply with these instructions could result in death or serious injury.

WARRANTY/REMEDY

Honeywell warrants goods of its manufacture as being free of defective materials and faulty workmanship during the applicable warranty period. Honeywell's standard product warranty applies unless agreed to otherwise by Honeywell in writing; please refer to your order acknowledgement or consult your local sales office for specific warranty details. If warranted goods are returned to Honeywell during the period of coverage, Honeywell will repair or replace, at its option, without charge those items that Honeywell, in its sole discretion, finds defective. **The foregoing is buyer's sole remedy and is in lieu of all other warranties, expressed or implied, including those of merchantability and fitness for a particular purpose. In no event shall Honeywell be liable for consequential, special, or indirect damages.**

While Honeywell may provide application assistance personally, through our literature and the Honeywell web site, it is buyer's sole responsibility to determine the suitability of the product in the application.

Specifications may change without notice. The information we supply is believed to be accurate and reliable as of this writing. However, Honeywell assumes no responsibility for its use.

Honeywell serves its customers through a worldwide network of sales offices, representatives and distributors. For application assistance, current specifications, pricing or name of the nearest Authorized Distributor, contact your local sales office or:

E-mail: info.sc@honeywell.com

Internet: sensing.honeywell.com

Phone and Fax:

USA/Canada +1-800-537-6945

International +1-815-235-6847; +1-815-235-6545 Fax

Honeywell Safety and Productivity Solutions

9680 Old Bailes Road

Fort Mill, SC 29707

www.honeywell.com

32313758-B-EN | 10/16
© 2016 Honeywell International Inc.

Honeywell