

Honeywell HumidCon™ Digital Humidity/Temperature Sensors: HIH-6130/6131 Series

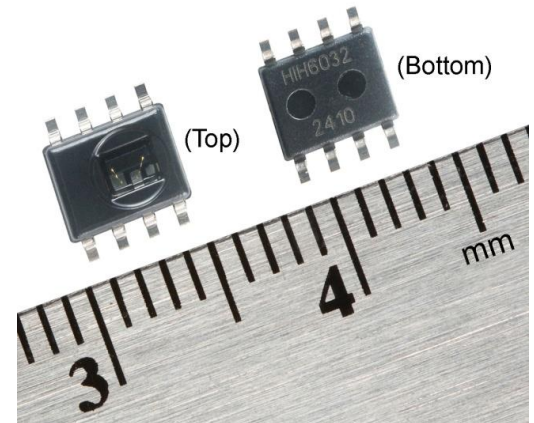

DESCRIPTION

Honeywell HumidCon™ Digital Humidity/Temperature Sensors: HIH-6130/6131 Series, is a digital output-type relative humidity (RH) and temperature sensor combined in the same package. These devices offer several competitive advantages, including:

- Industry-leading Total Error Band
- Industry-leading stability
- Industry-leading reliability
- Lowest total cost solution
- True temperature-compensated digital I²C output
- Energy efficiency
- Ultra-small package

★ Industry-leading Total Error Band (TEB) (± 5 %RH):

Honeywell specifies Total Error Band—the most comprehensive, clear, and meaningful measurement—that provides the sensor’s true accuracy of ± 5 %RH over a compensated range of 5 °C to 50 °C [41 °F to 122 °F] and 10% RH to 90% RH. TEB includes all errors due to:

- Humidity non-linearity
- Humidity hysteresis
- Humidity non-repeatability
- Thermal effect on zero
- Thermal effect on span
- Thermal hysteresis

Total Error Band should not be confused with “Accuracy”, which is actually a component of Total Error Band. Many competitors simply specify the accuracy of their device; however, the specification may exclude hysteresis and temperature effects, and may be calculated over a very narrow range, at only one point in the range, or at their absolute best accuracy level. It is then up to the customer to calibrate the device to make sure it has the accuracy needed for the life of the application.

Honeywell’s industry-leading Total Error Band provides the following benefits to the customer:

- Eliminates individually testing and calibrating every sensor, which can increase their manufacturing time and process
- Supports system accuracy and warranty requirements
- Helps to optimize system uptime
- Provides excellent sensor interchangeability—the customer can remove one sensor from the tape, remove the next sensor from the tape, and there is no part-to-part variation in accuracy

For more information about Total Error Band, please see the related Technical Note “Explanation of the Total Error Band Specification for Honeywell’s Digital Humidity/Temperature Sensors.”

★ Industry-leading long term stability (1.2% over five years):

Competitive humidity sensors need to go through a 12 hour at 75 %RH rehydration process (which requires special equipment chambers) to correct reflow temperature offset. Honeywell’s sensor also experiences an offset after reflow; however, it only requires a five hour rehydration under ambient conditions (>50 %RH). Honeywell’s industry-leading long term stability provides the following benefits to the customer:

- Minimizes system performance issues
- Helps support system uptime by eliminating the need to service or replace the sensor during its application life
- Eliminates the need to regularly recalibrate the sensor in their application, which can be inconvenient and costly

- ★ **Industry-leading reliability:** Honeywell’s new HIH-6130/6131 Series sensors use a laser trimmed, thermoset polymer capacitive sensing element. The element’s multilayer construction provides resistance to most application hazards such as condensation, dust, dirt, oils, and common environmental chemicals which help provide industry-leading stability and reliability.

Honeywell HumidIcon™ Digital Humidity/Temperature Sensors

- ★ **Lowest total cost solution:** Offers customers the lowest total cost solution due to the sensor's industry-leading Total Error Band and its being a combined humidity/temperature sensor.
- ★ **True, temperature-compensated digital I²C output:** Typically allows the customer to remove the components associated with signal conditioning from the PCB to free up space and reduce costs associated with those components (e.g., acquisition, inventory, assembly). Often eliminates problems that could occur from having multiple signal conditioning components across the PCB. Simplifies integration to the microprocessor, eliminating the need for customer-implemented, complex signal conditioning.
- ★ **Energy efficient**
 - **Low supply voltage:** Can operate down to 2.3 Vdc, which allows use in low energy and wireless-compatible applications to enhance energy savings and prolong system battery life.
 - **Low power consumption:** The sensor goes into sleep mode when not taking a measurement within the application, consuming only 1 µA of power versus 750 mA in full operation in a battery operated system. Sleep mode helps maximize battery life, reduces power supply size, and reduces the application's overall weight.
- ★ **Ultra-small package:** SOIC-8 SMD (Surface Mount Device) package is ultra small, including the condensation-resistant model with hydrophobic filter on-board (HIH-6131). Allows for flexibility of use within the application, occupies less space on the PCB, and typically simplifies placement on crowded PCBs or in small devices.
- **Combined humidity and temperature sensor:** The humidity and temperature sensors are co-located in the same package. This allows the RH measurement to be temperature compensated and provides a second, standalone temperature sensor output. This allows the user to purchase one sensor instead of two.
- **Tape and reel packaging:** Cost-effective tape-and-reel packaging allows for use in high volume, automated pick-and-place manufacturing, eliminating lead misalignment to the PCB and helping the customer to reduce manufacturing costs.
- **High resolution:** High 14-bit humidity sensor resolution and 14-bit temperature sensor resolution within the application help the user's system detect the smallest relative humidity or temperature change.

(★ = *competitive differentiator*)

FEATURES AND BENEFITS

- **Wide operating temperature range** of -25 °C to 85 °C [-13°F to 185 °F] allows for use in many applications
- **Optional one or two %RH level alarm outputs** provide the user the ability to monitor whether the RH level has exceeded or fallen below pre-determined and critical levels within the application
- **Multi-function ASIC** provides flexibility within the application by lowering or eliminating the risk and cost of OEM calibration
- **Industry-standard package** provides easy design-in
- **RoHS and WEEE compliant; halogen-free**
- **Two configurations** increase flexibility of use: HIH-6130: no filter, non-condensing; HIH-6131: hydrophobic filter and condensation-resistant allow use in many condensing environments

POTENTIAL APPLICATIONS

- **HVAC/R:** May be used to provide precision RH and temperature measurement in air conditioning/air movement systems, enthalpy sensing, thermostats, humidifiers/de-humidifiers, and humidistats to maintain occupant comfort and ideal storage humidity/temperature while achieving low energy consumption, supporting system accuracy and warranty requirements, maximizing system uptime, and improving overall system quality.
- **Respiratory therapy:** May be used to provide precision RH and temperature measurement in sleep apnea machines and ventilators, enhancing patient comfort, safety and treatment effectiveness with warm and humidified air.
- **Incubators/microenvironments:** May be used to provide optimal temperature and RH levels to support critical processes and experiments, enhancing process efficiency with desired climate conditions.
- **Air compressors:** May be used to provide precision RH measurement in compressed air lines, allowing the system to remove any condensation; dry compressed air is critical for customer process control measurement.
- **Weather stations:** May be used to provide precision RH and temperature measurement in ground-based and air-borne weather stations, allowing real time and highly accurate monitoring and reporting of actual weather conditions.
- **Telecom cabinets:** May be used to provide precision RH and temperature measurement in the telecom cabinet HVAC system; maintaining proper temperature and humidity levels in the cabinet provides maximum system uptime and performance.

HIH-6130/6131 Series

Table 1. Environmental Specifications

Characteristic	Condition	Min.	Typ.	Max.	Unit
Operating temperature range	–	-25 [-13]	–	85[185]	°C [°F]
Storage temperature range	–	-40 [-40]	–	85[185]	°C [°F]
Storage humidity	–	30	–	50	%RH
Soldering: automated	IPC/EIA/JEDEC J-STD-020D	–	–	260 [500]	°C [°F]
manual	apply heat for 4 s max. for manual soldering	–	–	350 [662]	
ESD	MIL-STD 883H, Method 3015.7	–	–	±4	kV
Latch-up immunity	–	–	–	±100	mA
Shock	MIL-STD 202G, Method 213D, Test Condition C, half-sine, 6 ms ±3 perpendicular axis, 3 shock pulses per axis	–	–	100	g
Vibration	MIL-STD 202G, Method 204D, Test Condition D, 10 Hz to 2000 Hz	–	–	20	g
Light sensitivity	exposed to 50 lumens yellow light; exhibited no change in output				

Table 2. Humidity Performance Specifications

Characteristic	Condition	Min.	Typ.	Max.	Unit
Supply voltage variation	2.3 Vdc to 5.5 Vdc	–	0.1	0.5	%RH
Compensated humidity range	–	10	–	90	%RH
Compensated temp. range	–	5 [41]	–	50 [122]	°C [°F]
Resolution	14 bit ADC resolution	–	–	0.04	%RH
Accuracy ¹	–	–	–	±4	%RH
Total error band ²	–	–	–	±5	%RH
Response time	airflow minimum 20 l/min	–	6	8	s
Operating range	non-condensing	0	–	100	%RH
Long term stability	50 %RH for 5 years	–	±0.05	±1.2	%RH
Impact of soldering	IPC/EIA/JEDEC J-STD-020D, peak temp. of 260 °C [500 °F]	–	–	±2.5	%RH

Notes:

- Accuracy is specified at the typical supply voltage of 3.3 Vdc and at 25 °C [77 °F]. It is the maximum deviation from the ideal transfer function of relative humidity measured over the humidity range of 10 %RH to 90 %RH and includes all errors due to humidity non-linearity, humidity hysteresis and humidity non-repeatability.
- Total error band is the maximum deviation from the ideal transfer function of relative humidity over the compensated range of 5 °C [41 °F] to 50 °C [122 °F]. It includes all errors due to humidity non-linearity, humidity hysteresis, humidity non-repeatability, thermal effect on zero, thermal effect on span and thermal hysteresis.

Table 3. Temperature Performance Specifications

Characteristic	Condition	Min.	Typ.	Max.	Unit
Supply voltage variation	2.3 Vdc to 5.5 Vdc	–	0.5	1.0	°C
Compensated temp. range	–	5 [41]	–	50 [122]	°C [°F]
Resolution	14 bit ADC resolution	–	–	0.025	°C
Accuracy (BFSL) ¹	–	–	–	±1.0	°C
Response time	1/e slow moving air	5	–	30	s
Long term stability	25 °C for 5 years	–	–	±0.05	°C/yr
Impact of soldering	IPC/EIA/JEDEC J-STD-020D, peak temp. of 260 °C [500 °F]	–	–	±0.1	°C

Note:

- Accuracy is specified over the compensated temperature range.

Table 4. Current Consumption

Characteristic	V _{DD}	Abbr.	Condition	Typ.	Max.	Unit
Sleep current	3.3	ISLEEP	–	0.6	1	µA
Supply current	3.3	IDD	14 bit fastest update, no sleep	0.65	1	mA

Honeywell HumidIcon™ Digital Humidity/Temperature Sensors

Table 5. Input and Output Characteristics

Characteristic	Abbr.	Condition	Min.	Typ.	Max.	Unit
Supply voltage	V _{DD}	–	2.3	3.3	5.5	V _{dc}
Low level output voltage	V _{OL}	I _{OL} = 2.8 mA min.	–	–	20%	V _{DD}
High level output voltage	V _{OH}	I _{OH} = -2.8 mA min.	80%	–	–	V _{DD}
Low level input voltage	V _{IL}	–	–	–	20%	V _{DD}
High level input voltage	V _{IH}	–	80%	–	–	V _{DD}
I ² C pull-up resistor	R _P	–	–	2.2	–	kOhm

Table 6. Measurement Timing

Characteristic	Abbr.	Condition	Min.	Typ.	Max.	Unit
Start-up time (Power-On to data ready)	T _{STA}	14 bit TH and 14 bit humidity resolution	–	50	60	ms
Update rate		application dependent: measurements are taken only when the application requests them				

Figure 1. I²C Timing

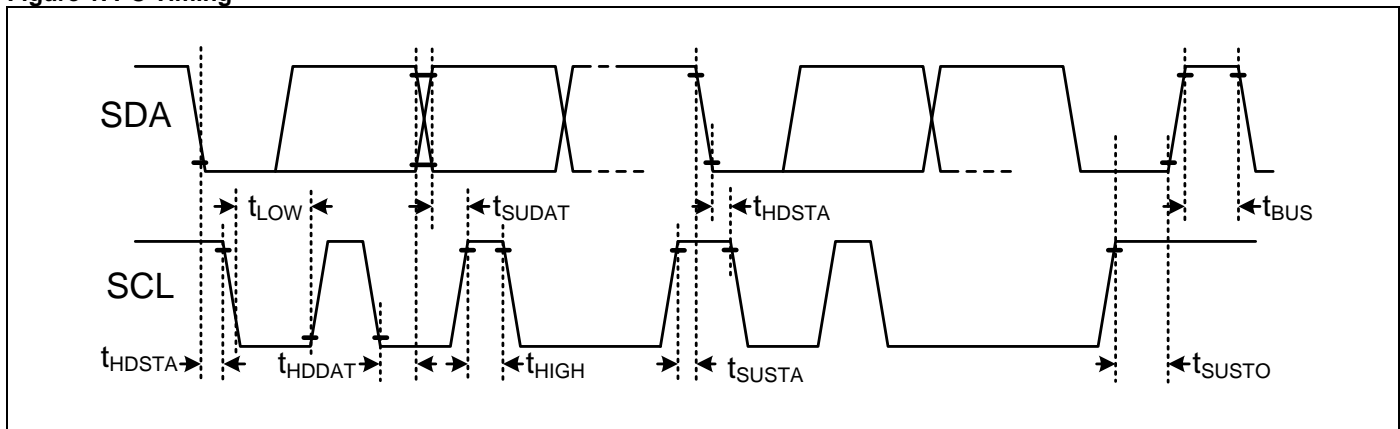

Characteristic	Abbr.	Min.	Typ.	Max.	Unit
SCL clock frequency	F _{SCL}	100	–	400	kHz
Start condition hold time relative to SCL edge	t _{HDSTA}	0.1	–	–	μs
Minimum SCL clock low width	t _{LOW}	0.6	–	–	μs
Minimum SCL clock high width	t _{HIGH}	0.6	–	–	μs
Start condition setup time relative to SCL edge	t _{SUSTA}	0.1	–	–	μs
Data hold time on SDA relative to SCL edge	t _{HDDAT}	0	–	–	μs
Data setup time on SDA relative to SCL edge	t _{SUDAT}	0.1	–	–	μs
Stop condition setup time on SCL	t _{SUSTO}	0.1	–	–	μs
Bus free time between stop and start condition	t _{BUS}	1	–	–	μs

Note: Combined low and high widths must equal or exceed minimum SCL period.

HIH-6130/6131 Series

Figure 2. Mounting Dimensions and Pinout (For reference only. mm/[in])

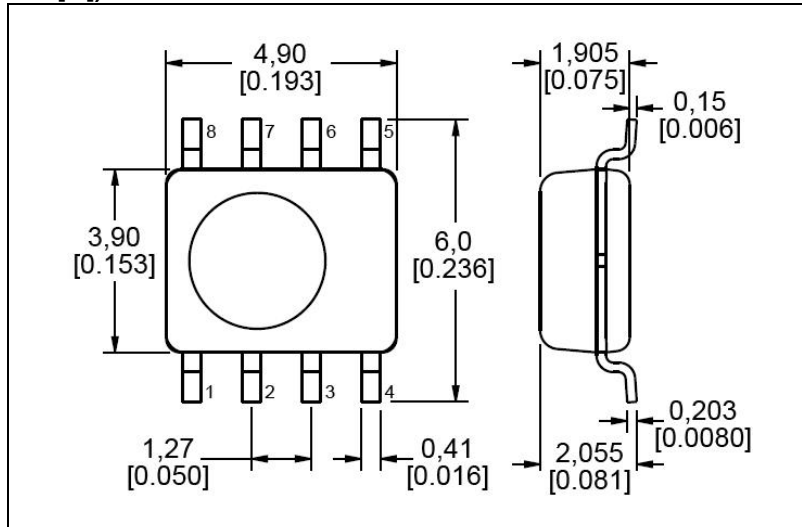
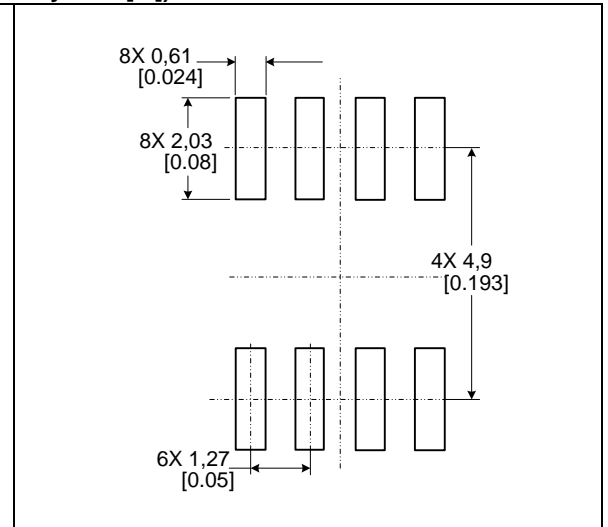

Figure 3. PCB Landing Pattern (For reference only. mm/[in])



Pin	ASIC Pad	Description
1	V _{CORE}	connect via 0.1 μF to ground
2	V _{SS}	supply ground
3	SCL	I ² C clock
4	SDA	I ² C data
5 ¹	AL_H	alarm output high
6 ¹	AL_L	alarm output low
7	NC	not connected externally
8	V _{DD}	supply voltage, connect via 0.22 μF to ground

Note:

- Do not connect Pin(s) 5 and/or 6 if the built-in alarm feature is not desired.

Figure 4. Typical Application Circuit

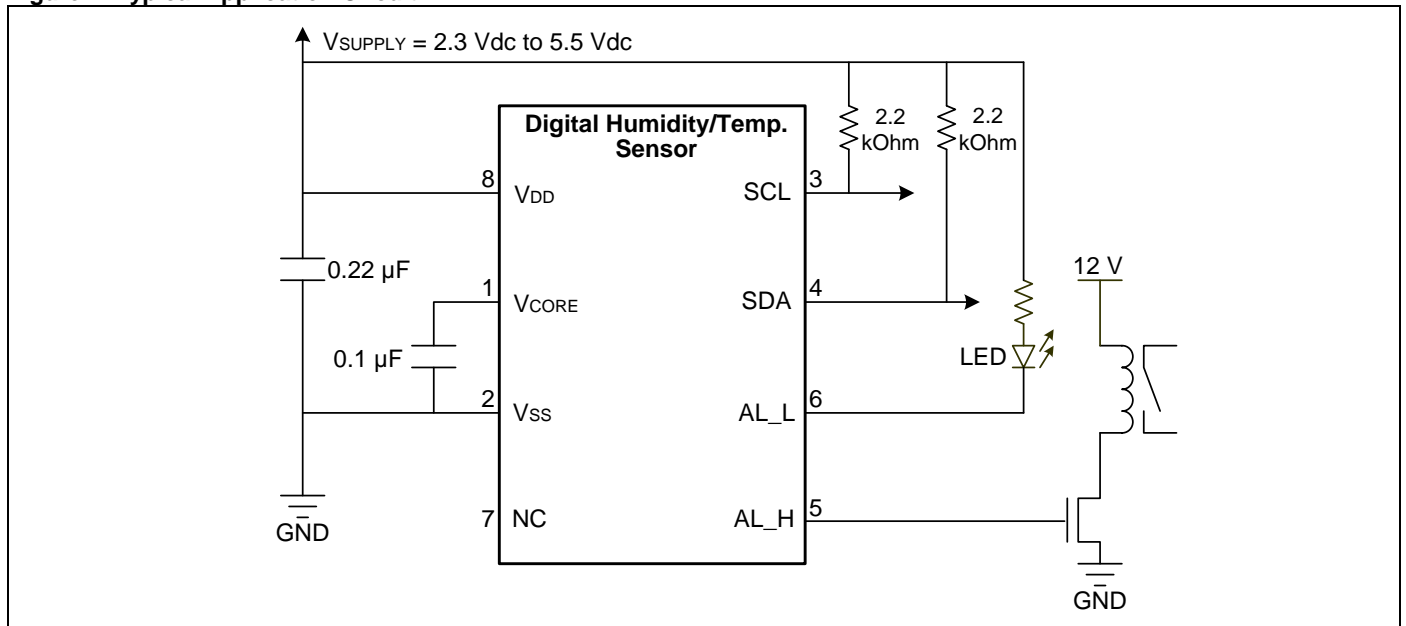

Honeywell HumidIcon™ Digital Humidity/Temperature Sensors

Table 7. HIH-6130/6131 Series Maximal Accuracy¹ (Performance is specified between 10 %RH and 90 %RH.)

Relative Humidity (%RH)	90	±1	±2	±2	±2	±3	±3	±3	±3	±3	±2
		±1	±2	±2	±2	±3	±3	±3	±3	±3	±2
	80	±1	±2	±2	±2	±2	±2	±2	±2	±2	±1
		±2	±2	±2	±2	±2	±2	±2	±2	±2	±2
	70	±2	±3	±3	±3	±2	±2	±2	±2	±2	±2
		±2	±3	±3	±3	±3	±3	±3	±3	±3	±2
	60	±2	±3	±3	±3	±3	±3	±3	±3	±3	±2
		±2	±3	±3	±3	±3	±3	±3	±3	±3	±2
	50	±2	±3	±3	±3	±3	±3	±3	±3	±3	±2
		±2	±3	±3	±3	±3	±3	±3	±3	±3	±2
	40	±2	±3	±3	±3	±3	±3	±3	±3	±3	±2
	±2	±3	±3	±3	±3	±3	±3	±3	±3	±2	
30	±2	±3	±3	±3	±3	±3	±3	±3	±3	±2	
	±2	±3	±3	±3	±3	±3	±3	±3	±3	±2	
20	±1	±3	±3	±3	±3	±3	±3	±3	±3	±1	
	±1	±3	±3	±3	±3	±3	±3	±3	±3	±1	
10	±1	±3	±3	±3	±3	±3	±3	±3	±3	±1	
0		10	20	30	40	50					
		Temperature (°C)									

Note:

1. Maximal accuracy is the mean value between rising and falling RH points.

Figure 5. Tape and Reel Dimensions (For reference only. mm/[in])

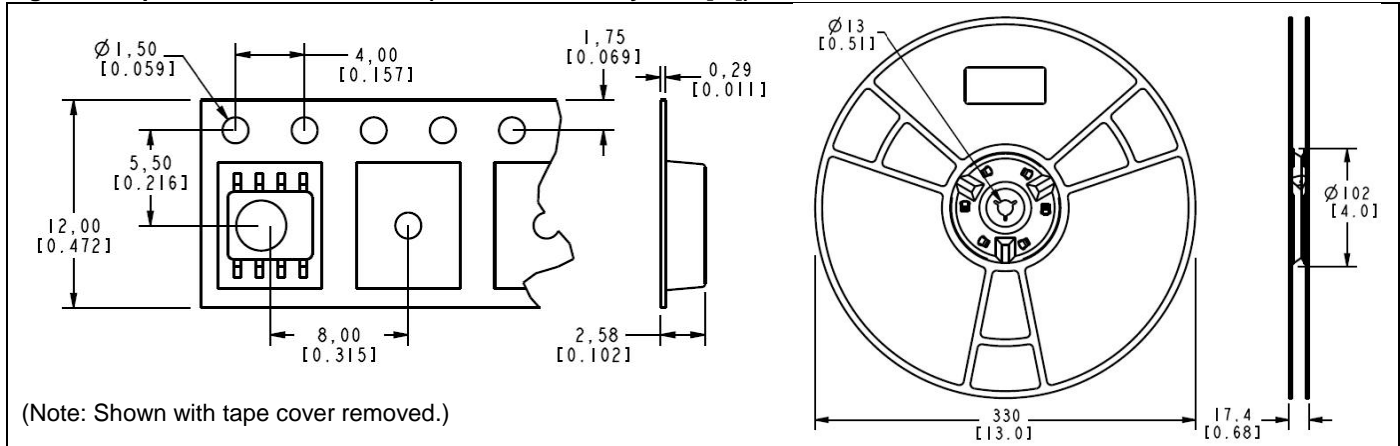

HIH-6130/6131 Series

Figure 6. Nomenclature

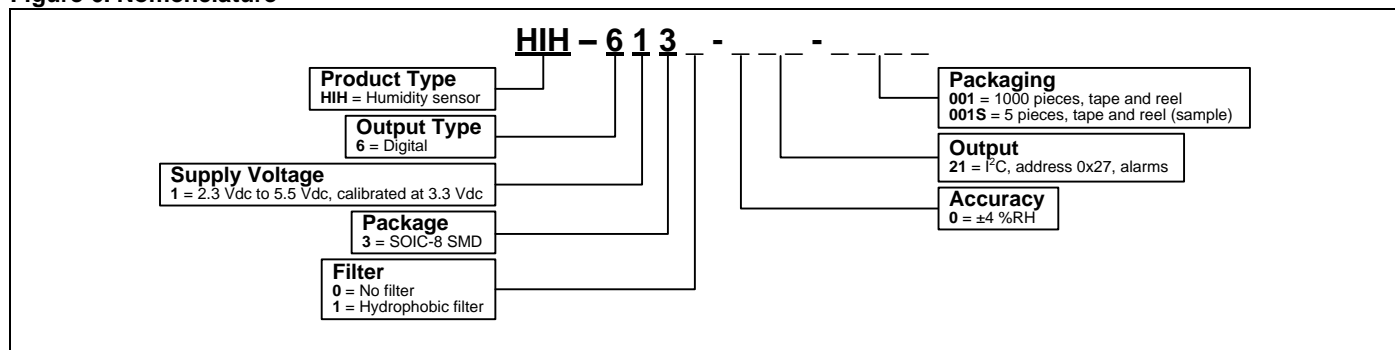

Order Guide

Catalog Listing	Description
HIH-6130-021-001	Honeywell HumidCon™ Digital Humidity/Temperature Sensors: HIH-6130/6131 Series, I ² C, ±5 %RH total error band, SOIC-8 SMD, no filter, non-condensing, 1000 units on tape and reel
HIH-6130-021-001S	Honeywell HumidCon™ Digital Humidity/Temperature Sensors: HIH-6130/6131 Series, I ² C, ±5 %RH total error band, SOIC-8 SMD, no filter, non-condensing, five units on tape (sample)
HIH-6131-021-001	Honeywell HumidCon™ Digital Humidity/Temperature Sensors: HIH-6130/6131 Series, I ² C, ±5 %RH total error band, SOIC-8 SMD, hydrophobic filter, condensation-resistant, 1000 units on tape and reel
HIH-6131-021-001S	Honeywell HumidCon™ Digital Humidity/Temperature Sensors: HIH-6130/6131 Series, I ² C, ±5 %RH total error band, SOIC-8 SMD, hydrophobic filter, condensation-resistant, five units on tape (sample)

SENSOR REHYDRATION

NOTICE

SENSOR REHYDRATION

- Exposure to elevated temperatures, such as those experienced during solder reflow, may dry out the sensing element. It is recommended that the sensor be allowed time to rehydrate after soldering or other high temperature/dry exposures.
- Exposure to these conditions will not permanently damage the sensor. It will generally return to its factory-calibrated value after rehydration.
- If rehydration is not performed, the sensor may read a slight offset that slowly disappears over time as the sensor becomes exposed to ambient conditions. Conversely, extended exposure to condensing and high humidity environments (>90 %RH) may cause a revisable shift in readings which will generally return to normal after the sensor has been allowed to dry off.

To rehydrate the sensor, expose it to room temperature under ambient conditions (>50 %RH) for a minimum of five hours.

ADDITIONAL INFORMATION

The following associated literature is available on the [Web](#):

- Product installation instructions
- Product application note
- Application sheets:
 - Humidity Sensor Performance Characteristics
 - Humidity Sensor Theory and Behavior
 - Humidity Sensor Moisture and Psychrometrics
 - Humidity Sensor Chemical Resistivity
 - Thermoset Polymer-based Capacitive Sensors
- Technical Notes:
 - I²C Communication with the Honeywell HumidCon™ Digital Humidity/Temperature Sensors: HIH-6130/6131 Series
 - Using Alarms on the Honeywell HumidCon™ Digital Humidity/Temperature Sensors: HIH-6130/6131 Series
 - Entering and Using Command Mode on the Honeywell HumidCon™ Digital Humidity/Temperature Sensors: HIH-6130/6131 Series
 - Total Error Band Specification for Honeywell Digital Humidity/Temperature Sensors

WARNING

MISUSE OF DOCUMENTATION

- The information presented in this product sheet is for reference only. Do not use this document as a product installation guide.
- Complete installation, operation, and maintenance information is provided in the instructions supplied with each product.

Failure to comply with these instructions could result in death or serious injury.

WARRANTY/REMEDY

Honeywell warrants goods of its manufacture as being free of defective materials and faulty workmanship. Honeywell's standard product warranty applies unless agreed to otherwise by Honeywell in writing; please refer to your order acknowledgement or consult your local sales office for specific warranty details. If warranted goods are returned to Honeywell during the period of coverage, Honeywell will repair or replace, at its option, without charge those items it finds defective. **The foregoing is buyer's sole remedy and is in lieu of all other warranties, expressed or implied, including those of merchantability and fitness for a particular purpose. In no event shall Honeywell be liable for consequential, special, or indirect damages.**

While we provide application assistance personally, through our literature and the Honeywell web site, it is up to the customer to determine the suitability of the product in the application.

Specifications may change without notice. The information we supply is believed to be accurate and reliable as of this printing. However, we assume no responsibility for its use.

WARNING

PERSONAL INJURY

DO NOT USE these products as safety or emergency stop devices or in any other application where failure of the product could result in personal injury.

Failure to comply with these instructions could result in death or serious injury.

SALES AND SERVICE

Honeywell serves its customers through a worldwide network of sales offices, representatives and distributors. For application assistance, current specifications, pricing or name of the nearest Authorized Distributor, contact your local sales office or:

E-mail: info.sc@honeywell.com

Internet: www.honeywell.com/sensing

Phone and Fax:

Asia Pacific	+65 6355-2828 +65 6445-3033 Fax
Europe	+44 (0) 1698 481481 +44 (0) 1698 481676 Fax
Latin America	+1-305-805-8188 +1-305-883-8257 Fax
USA/Canada	+1-800-537-6945 +1-815-235-6847 +1-815-235-6545 Fax

Sensing and Control
Honeywell
1985 Douglas Drive North
Golden Valley, MN 55422
www.honeywell.com/sensing

009059-1-EN IL50 GLO Printed in USA
June 2011
© 2011 Honeywell International Inc. All rights reserved.

Honeywell